

PERFORMANCE DATA

FEEDER (STAGE V)

BMF 2500

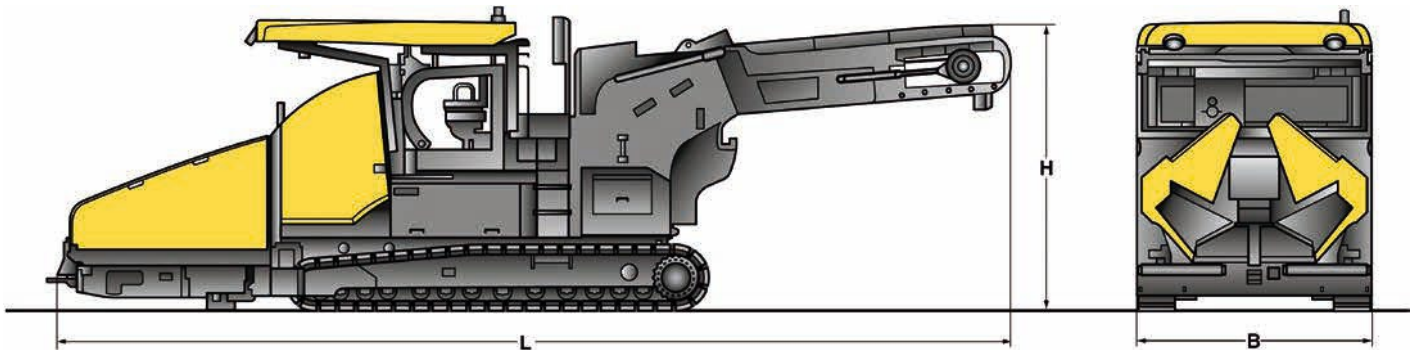



Transport dimensions in m

	Length	Width	Height
BMF 2500 S	9.25	2.55	3.10
BMF 2500 M	10.26	2.55	3.10
BMF 2500 S OC 650	15.30	2.55	3.10

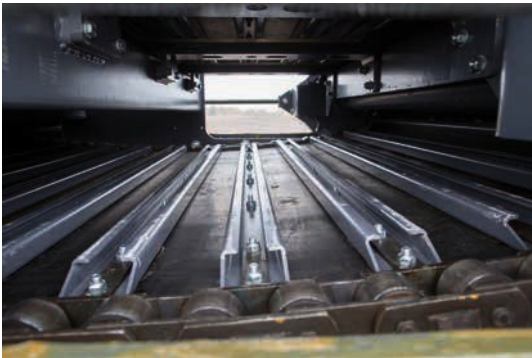

Work reliably – the chain-reinforced conveyor belt prevents downtime.



Flexible in use – the optionally available swivel belt with 6.5 m (OC 650) for BMF 2500 S.



Prevent demixing – 1.20 m width ensures smooth material transport.



Everything in view – the lift platform offers the best overview.

Technical data

BOMAG BMF 2500

Weights CECE

BMF 2500 S	kg	20000
BMF 2500 M	kg	21000
BMF 2500 S OC 650	kg	24500

Dimensions

Transport length BMF 2500 S	mm	9250
BMF 2500 M	mm	10260
BMF 2500 S OC 650	mm	15300
Transport width BMF 2500 S	mm	2550
BMF 2500 M	mm	2550
BMF 2500 S OC 650	mm	2550
Transport height	mm	3100
Approach angle	°	10

Travel characteristics

Travel speed	km/h	0-4
Working speed	m/min	0-25 variable

Drive

Engine manufacturer		Cummins
Type		B6.7-C225
Exhaust classification		Stage V / T4f
Cooling system		Fluid
Number of cylinders		6
Displacement	cm ³	6700
Power	kW / PS	168 / 225
Rated speed	U/min	2200

Track-chain chassis

Overall length	mm	3950
Width	mm	320

Hopper

Capacity	m ³ / t	7 / 15
Width (wings open)	mm	3550
Width (wings closed)	mm	2550
Length	mm	2250
Filling height (middle)	mm	580

Conveyor belt

Type		Rubber band, mounted on two roller chains, with metal cross braces Infinitely adjustable
Speed		
Width	mm	1200
Feed height BM 2500 S / BMF 2500 M	mm	2180 mm (with hydraulic height adjustment 2560 mm)
Förderhöhe BM 2500 S OC 650	mm	1100-4150 (hydr. (hydr. height adjust- ment)
Capacity	t/h	up to 4000

Filling capacities

Fuel	l	360
Hydraulic oil	l	200

Electric system

Voltage	V	24
---------------	---	----

Technical modifications reserved. Machines may be shown with optional accessories. Actual machine weight depends on the respective configuration.

Standard equipment

Operator's platform

- 2 drivers' seats, swivelling and rotating
- Protection, dashboard
- Adjustable dashboard
- Hydraulically foldable roof
- Digital machine management display
- Weather protection roof
- Height-adjustable lift platform

Tractor

- Individual control of the hopper wings
- Chain scrapers
- Rubber track pads
- Hydr. hopper front gate
- Cleaning kit
- Slewing belt pre-fitting (BMF 2500 S)
- Central lubrication for conveyor belt

Conveyor belt

- Scraper for conveyor belt
- Automatic cleaning system for conveyor belt
- LED lighting for swivel belt
- Hydraulic height adjustment for conveyor belt

Assistance systems

- On-board tools
- Automatic distance control
- Automatic loading assistant
- Laptop station
- LED roof lighting

Miscellaneous

- 7 halogen working lights
- Flashing beacon
- Reversing buzzer
- 2 x 24 V sockets
- 2 x 12 V sockets
- Storage compartments

Optional equipment

Operator's platform

- Weather protection for platform
- Comfort seat with seat heating
- Comfort seat with joystick

Tractor

- Special paintwork
- Biodegradable hydraulic oil
- Camera system (compatible with swivel belt)
- Stop light system
- FLEXMIX Basis (2 conical augers in the hopper)

Conveyor belt

- Swivel belt OC 650
(only for model BMF 2500 S incl. cover)

Assistance systems

- Automatic steering system (max. 14.0 M)
- Automatic steering system (max. 10.0 M)

Miscellaneous

- BOMAG TELEMATIC fleet management
- Light balloon (24 V, 250 W)
- Fire extinguisher
- Safety package with coming home function
- Engine compartment lighting

