

# TECHNICAL DATA

SOIL COMPACTOR

BC 773 EB-5

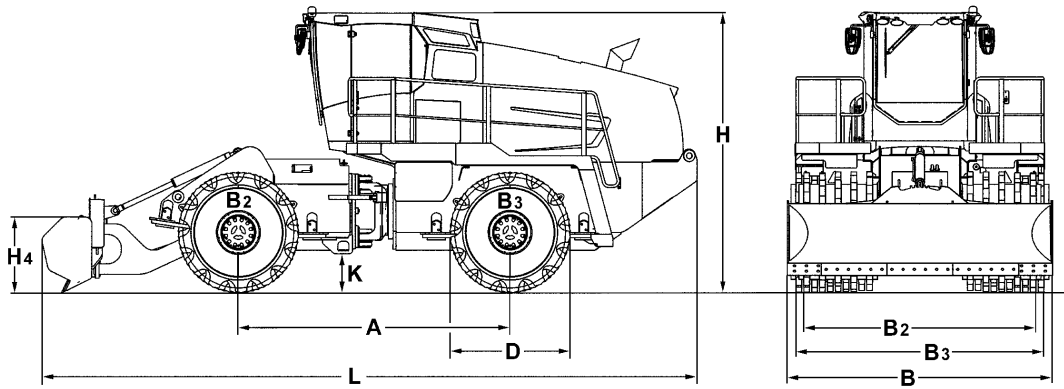



**Dimensions in mm**

	<b>A</b>	<b>B</b>	<b>B2</b>	<b>B3</b>	<b>D</b>	<b>H2</b>	<b>H4</b>	<b>K</b>	<b>L</b>
<b>BC 773 EB-5</b>	3890	3800	3692	3467	1725	4016	1050	600	9490

**Shipping dimensions in m3**

<b>BC 773 EB-5</b>	144,825
--------------------	---------

## Technical Data

## BOMAG BC 773 EB-5

### Weights

Grossweight .....	kg	37.250
Operating weight CECE .....	kg	36.650
Axle load, front / rear CECE .....	kg	17.950/18.700

### Driving Characteristics

Speed (1), forward .....	km/h	0- 12,0
Speed (1), reverse .....	km/h	0- 12,0
Max. gradeability (dep. on soil con.) .....	%	100
Max. pushing force .....	kN	346

### Drive

Engine manufacturer .....		Merc.-Benz
Type .....		OM 471 LA
Emission stage .....		Stage V / TIER4f
Exhaust gas aftertreatment .....		DOC+DPF+SCR
Cooling .....		Liquid
Number of cylinders .....		6
Performance ISO 9249 .....	kW	340,0
Performance SAE J 1349 .....	hp	456,0
Speed .....	min-1	1.700
Travel system .....		hydrost.
Operating voltage .....	V	24

### Compaction Wheels

Width, front / rear .....	mm	1.125/1.125
Outer diameter (front) .....	mm	1.725
Outer diameter (rear) .....	mm	1.725
Number of teeth/cutters, front .....		65
Number of teeth/cutters, rear .....		65
Compaction coverage per side .....	mm	1.238

### Brakes

Service brake .....		hydrost.
Parking brake .....		hydromec.

### Steering

Steering system .....		oscil.artic.
Steering method .....		hydraulic
Steering / oscillating angle +/- .....	grad	40/15
Track radius, inner .....	mm	3.756

### Dozer Blade

Height adjustment over ground level .....	mm	1.200
Height adjustment below ground level .....	mm	120

### Capacities

Fuel .....	l	650,0
Engine oil .....	l	39,0
Hydraulic oil .....	l	350,0
AdBlue (DEF) ® .....	l	40,0

Technical modifications reserved. Machines may be shown with options.

## Standard Equipment

## Optional Equipment

- Compaction wheels, teeth with replaceable caps
- Premium compaction wheels with highly wear resistant teeth
- Soil compactor dozer blade (3800mm)
- Dozer blade with tilting mechanism
- Fire extinguisher
- Special painting
- Environmentally compliant engine oil
- Protective ventilation system (Pre-installation)
- Cold start device 115V
- Cold start device 230V
- TELEMATIC POWER

